

SDX Auger Filler

The Technology

- 1 High torque servo drive for auger tooling
- 2 Separate drive for agitator
- 3 Height adjustment with hydraulic jack for minimum product drop
- 4 Split design product hopper with window for easy cleaning and tooling change
- 5 Low profile design for low ceiling height
- 6 Level probe to control product infeed

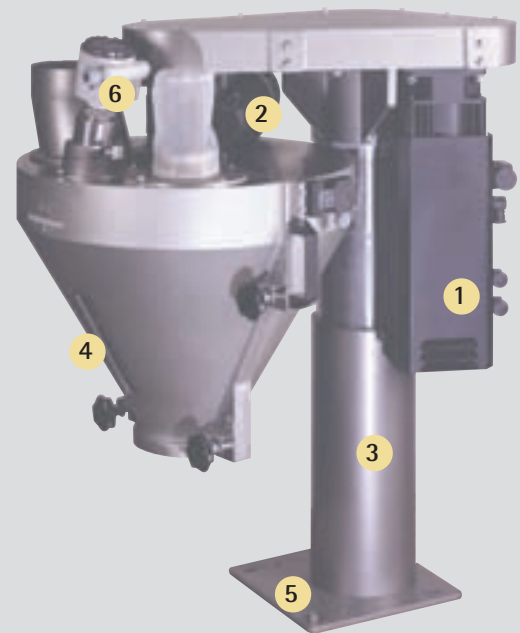

The Function

- 1 Product Infeed
- 2 Drive for agitator
- 3 Agitator distributes the product inside the hopper
- 4 Servo drive for auger tooling
- 5 Level Probe
- 6 Product Discharge

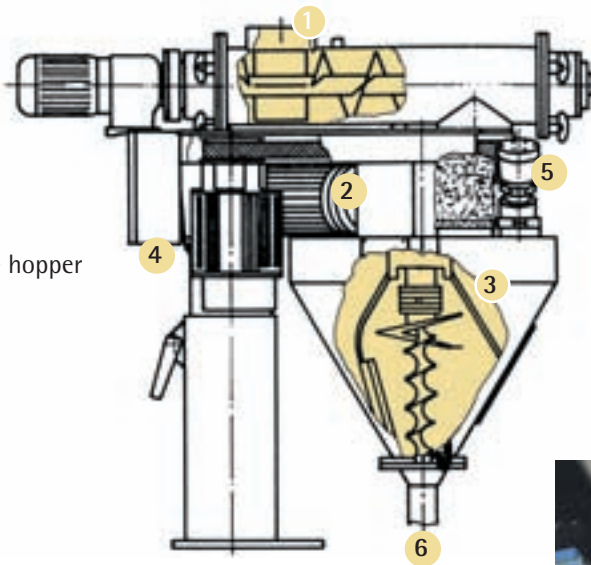



The Product Line

- Vertical form-fill-seal machines
- Horizontal form-fill-seal machines
- Cartoners
- Casepackers
- Display Packers
- Auger Fillers
- Cupfeeders
- Transfer Systems
- Bag-in-Box Lines
- Turnkey Systems

The Focus

ROVEMA, a global leader in total packaging technology, offers a complete line of high quality machines and integrated systems which simplify the packaging process. From flexible bags and pouches to folding cartons and cases, ROVEMA meets all your packaging needs.

With a strong focus on customer service, research and development, and over 40 years of engineering and applications experience, ROVEMA is delivering the quality and technology needed to achieve the highest production efficiencies in the industry. The fully synchronized product lines offer state-of-the-art methods to create and distribute the newest packaging designs of customers all around the world.

The Product

The SDX auger fills efficiently and accurately a wide variety of different products from very fine powders to granulated items such as:

- Cake Mix
- Milk Powder
- Powdered Sugar
- Coffee
- Flour
- Corn Meal
- Gravy Mix
- Spices
- Chemical Products

The Filling System

Rovema has extensive experience in the packaging of powders and granulated items. The SDX auger, featuring smooth product handling and high accuracy, meets all the requirements of modern filling and packaging technology.

The quality auger tooling is made to match the specific product requirements. Special closure devices are available to prevent any product dribble. Also optional items, such as gas flushing and dust extraction, can be added.



ROVEMA

SDX Auger Filler

Servo Driven Auger Filler For Highest Accuracy





ROVEMA

Your Packaging Partner Into the Future

GERMANY
 ROVEMA
 Verpackungsmaschinen GmbH
 Industriestrasse 1
 D 35461 Fernwald
 Tel: ++ 641-409-0
 Fax: ++ 641-409-212
 Email: info@rovema.de
 http://www.rovema.de

ROVEMA
 Endverpackungstechnik GmbH
 Industriestrasse 1
 D 35461 Fernwald
 Tel: ++ 641-409-0
 Fax: ++ 641-409-212
 Email: info@rovema.de
 http://www.rovema.de

SPAIN
 ROVEMA Iberica S.A.
 Pau Claris, 147-161, Apdo. 318
 E 08205 Sabadell (Barcelona)
 Tel: ++ 93-7 26 12 00
 Fax: ++ 93-7 26 27 03
 Email: rovema@dracnet.es

UNITED STATES OF AMERICA
 ROVEMA
 Packaging Machines L.P.
 650 Hurricane Shoals Rd., NW
 Lawrenceville, GA 30045 U.S.A
 Tel: ++ 770-5 13 96 04
 Fax: ++ 770-5 13 08 14
 Email: sales@rovema.com
 http://www.rovema.com

UNITED KINGDOM
 ROVEMA
 Packaging Machines Limited
 9A Alton House Office Park
 Gatehouse Way, Aylesbury
 Bucks HP 19 3XU,
 Tel: ++ 12 96-48 32 36
 Fax: ++ 12 96-48 73 04
 Email: sales@Rovema.co.uk

NETHERLANDS
 ROVEMA Benelux bv
 Heulweg 20, 4931 ND
 Postbus 11, 4930 AA
 NL Geertruidenberg
 Tel: ++ 162-576 464
 Fax: ++ 162-576 465
 Email: sales@rovemabenelux.nl

ITALIA
 ROVEMA Italia S.R.L.
 Viale Paolo Onarato
 Vigliani, 21
 I 20 148 Milano
 Tel: ++ 02-48 01 17 85
 Fax: ++ 02-48 00 82 59
 Email: RIT@galactica.it

AUSTRIA
 ROVEMA
 Verpackungsmaschinen Ges.m.b.H.
 Neusiedlerstr. 54 1/2
 A 2340 Mödling
 Tel: ++ 22 36-4 64 85
 Fax: ++ 22 36-4 64 53
 Email: rovema@Eunet.at

ASIA
 ROVEMA Asia
 60, Albert Street #09-05
 Albert Complex
 1899 69 Singapore
 Tel: ++ 339 01 26
 Fax: ++ 339 22 09
 Email: rasmd@singnet.com.sg

... and sales and Service centers
 worldwide

SDX AUGER FILLER

TECHNICAL DATA

SDX

Volume Range	2 – 30,000 ccm
Output	180 cycles/min
Positioning accuracy of auger	.05°
Weight	450 lbs. (205 kgs.)
Power Supply	230/460V/60 Hz.
Height (H)	41 1/2" – 49" (1,055 – 1,245 mm)
Width (W)	25 3/4" (655 mm)
Length (L)	47 1/4" (1,200 mm)

Operating data depends on machine speed, options, product, filling and film characteristics.
 Technical data and dimensions subject to change without notice.

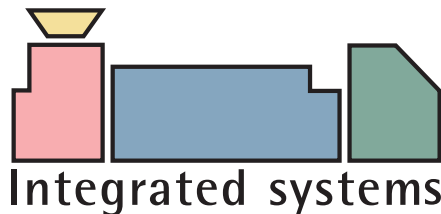
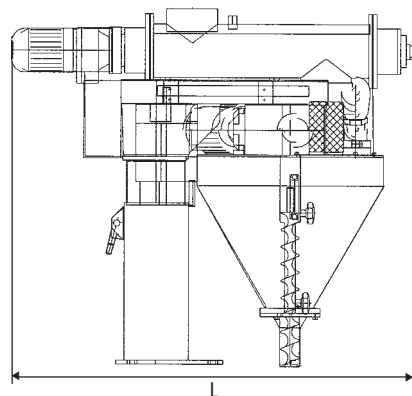
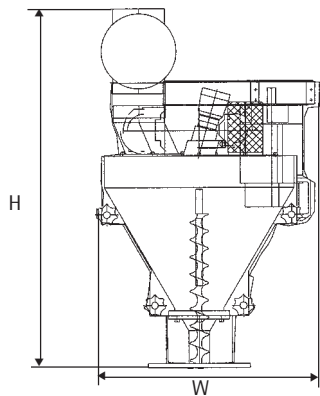

ROVEMA Packaging Machines L.P.
 650 Hurricane Shoals Rd., NW
 Lawrenceville, GA 30045
 Phone: (770) 513-9604
 Fax: (770) 513-0814
 www.rovema.com
 Email: sales@rovema.com